

# Vermeer®

HYDROSTATIC TRENCH  
COMPACTOR

# TC-4a



# Vermeer®

# TC-4a

HYDROSTATIC TRENCH  
COMPACTOR

## Triple the shaker force

The Vermeer TC-4a delivers 16,000 lbs. (7258 kg) of shaker force and is powered by a 20 HP (15 kw) Hatz engine — the proven engine in trench compactors. So even when faced with jobs that appear to require much heavier, higher-horsepower equipment, the TC-4a pounds them into submission.

## Half the weight

At less than 3,000 lbs. (1361 kg), the TC-4a weighs in as the industry's lightest compactor. Plus, its distinctive, compact design makes cutting through narrow fence openings and maneuvering in tight working conditions a breeze (a sound you may hear when using the optional Hatz engine sound package, may we add).

## More Compaction Where You Need It, Less Where You Don't



*Optional Towing Package  
The TC-4a is in a class by itself with an optional Vermeer towing package, which eliminates the need for a trailer and makes transport to and from the job site less costly, in time and money.*



*Shaker Force  
The TC-4a pounds out 16,000 lbs. (7258 kg) worth of shaker force thanks to a unique dry shaker box design that transfers force directly to the ground rather than inefficiently spinning the weights in oil — an innovation that has made it the uncontested leader in productivity.*



*Optional Tilt Frame*  
 The compaction unit is free to adjust to inclinations up to 10 degrees inside the frame, a design which allows the TC-4a to remain true to vertical trenches dug in by tilt trenchers.



*Narrow, Lightweight Design*  
 The TC-4a's narrow, 57" (145 cm) width is ideal for jobs that ask you to squeeze through restricting entrances. And because there are fewer than 3000 lbs. (1361 kg) to pull around, you won't have to sidestep around delicate landscaping, either.

## TC-4a Specifications

### General

Weight: 2960 lbs. (1343 kg)  
 Length: 99.7" (253.2 cm)  
 Height: 62.3" (158.2 cm)  
 Width: 57" (145 cm)

### Engine

Model: Hatz 2640 Diesel  
 Maximum no load RPM: 3000  
 Maximum gross horsepower:  
 20 HP (15 kw)  
 Cooling medium: Air-cooled  
 Air cleaner: Dual-element foam and paper  
 Oil filter: Full-flow  
 Fuel capacity: 6.5 gal. (24.6 L)  
 Electrical system: 12-volt  
 Fuel consumption: 1.0 gph (3.7 Lph),  
 fully-loaded  
 Hour meter: Standard

### Ground Drive

Tamping speed: 0 – 38 fpm  
 (0 – 11.6 m/min.)  
 Transport speed: 0 – 190 fpm  
 (0 – 57.9 m/min.)  
 Control: Mono stick — fwd./rev. steering  
 Variable speed control  
 Front drive axle: No-spin

### Tamper Wheel

Size: 42" (107 cm) diameter,  
 2" (5 cm) wide  
 Depth: 0 – 26" (0 – 66 cm)

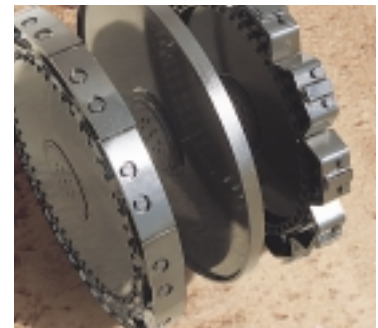

Smooth or sheep's foot tamping wheels are available with 4", 6", 8" and 11" (10 cm, 15 cm, 20 cm, and 28 cm) bolt-on pads. Narrow-width wheel (center), 2" (5 cm) size only.

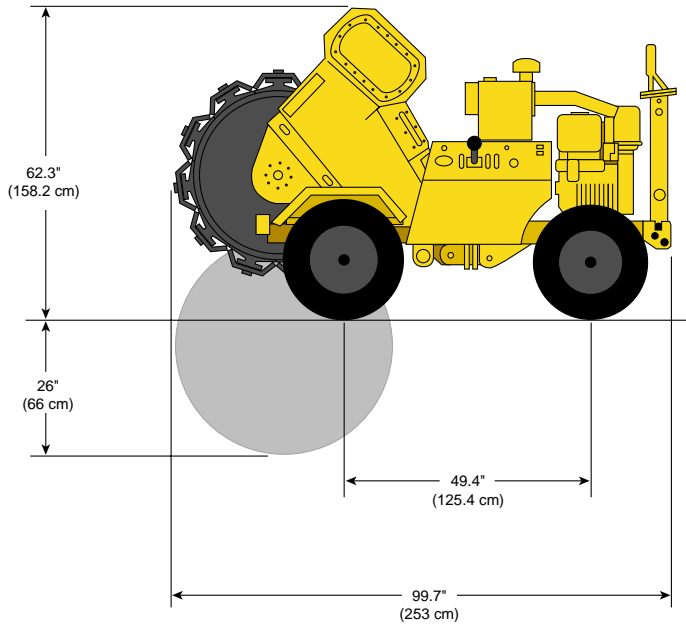
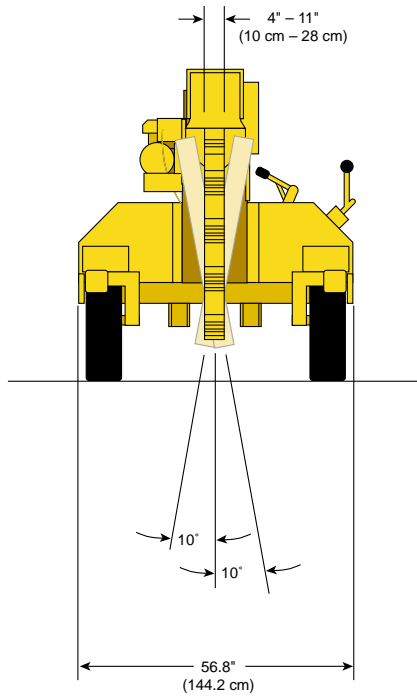

## TC-4a Specifications

### Vibrator

Frequency: 1600 RPM

Force: 8000 – 16,000 lbs. (3629 – 7258 kg)

Weights: Bolt-on

Dry-type shaker

### Frame

Style: Unitized, welded construction

Tire size: Rear trailer: B78R13

Front drive: 23 x 10.5-12

Brakes: Optional electric

Hitch type: Clevis-pin or pintle

Park brake: Standard

Jack stand: Screw-type, 15" (38 cm)

travel, electric optional

Lights: Stop and turning sealed lens/bulb

Safety chain: Double safety towing chains

Tongue weight: 562 lbs. (255 kg)

Towing speed: 65 mph (105 kmph)

### Options

Towing package

Hatz engine sound package

Tilt frame

*Your Vermeer dealer is independent and authorized to be a Vermeer specialist who knows your local conditions and is ready to provide expert support, service and parts, wherever your job site.*



## Vermeer Manufacturing Company

P.O. Box 200

Pella, Iowa 50219 U.S.A.

Phone: (515) 628-3141

Fax: (515) 621-7734

*(Europe, Middle East and Africa Inquiries:)*

Vermeer International

P.O. Box 323

4460 AS Goes

Netherlands

Phone: +31 113 272700

Telex: 55388 vrmer nl

Fax: +31 113 272727

For more information, call:

**1-800-829-0051**

*(U.S.A. only)*

International fax: (515) 621-7730

[www.vermeer.com](http://www.vermeer.com)

